

Classic 1" Tweeter



Type Number: D2905/970000

Features:

The Classic line consists of all the highly regarded ScanSpeak transducers that have been appraised and loved by so many customers over the years. The goal has been to assemble all the diamonds, developed over the years, speakers that fully live up to the heritage of the ScanSpeak brand.

Driver Highlights: 1" soft dome, SD-2 motor, low compression design, non resonant chamber



Specs:

Electrical Data

Nominal impedance	Zn	6	ohm
Minimum impedance	Zmin	--	ohm
Maximum impedance	Zo	--	ohm
DC resistance	Re	4.7	ohm
Voice coil inductance	Le	0.01	mH

T-S Parameters

Resonance Frequency	fs	500	Hz
Mechanical Q factor	Qms	--	
Electrical Q factor	Qes	--	
Total Q factor	Qts	--	
Force factor	Bl	3.5	Tm
Mechanical resistance	Rms	--	Kg/s
Moving mass	Mms	0.45	g
Suspension compliance	Cms	--	mm/N
Effective cone diameter	D	--	cm
Effective piston area	Sd	8.5	cm ²
Equivalent volume	Vas	--	ltrs
Sensitivity		89.5	dB

Power handling

100h RMS noise test (IEC)	225	W
Long-term Max System Power (IEC)	--	W
Short Term Max power	--	W

Voice Coil and Magnet Parameters

Voice coil diameter	28	mm
Voice coil height	--	mm
Voice coil layers	--	
Height of the gap	--	mm
Linear excursion +/-	0.4	mm
Max mech. excursion +/-	1.5	mm
Flux density of gap	--	mWb
Total useful flux	--	mWb
Diameter of magnet	--	mm
Height of magnet	--	mm
Weight of magnet	--	Kg

Frequency:

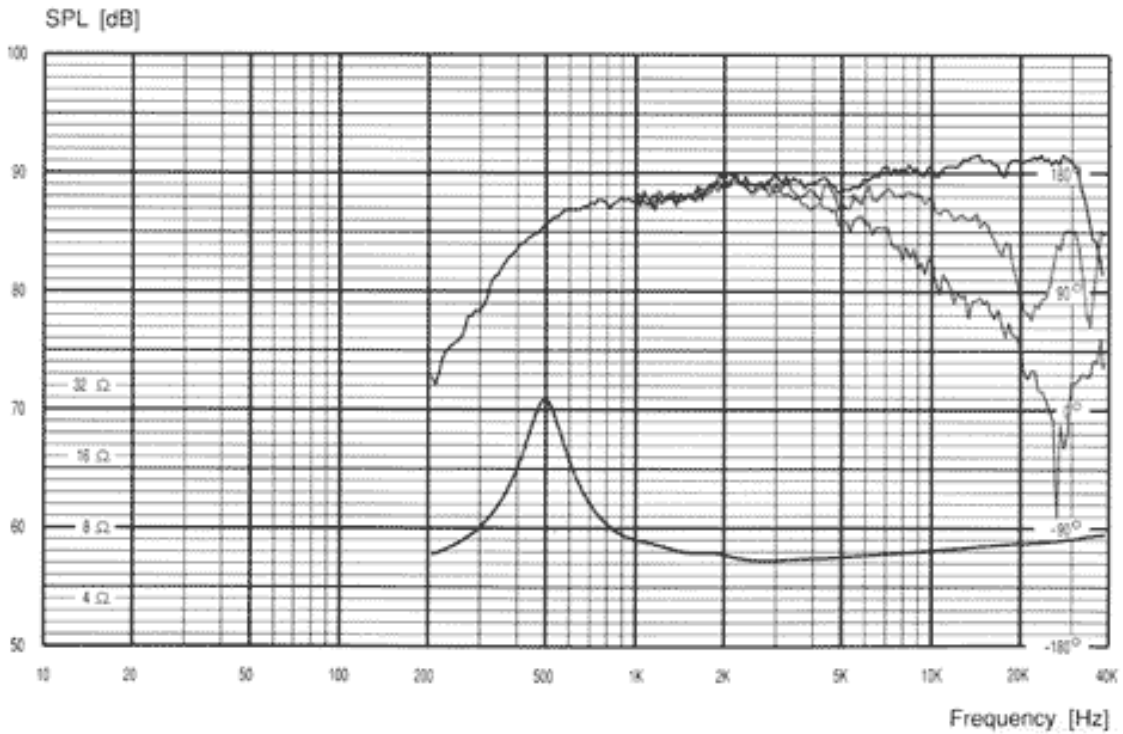

Mechanical Dimensions:

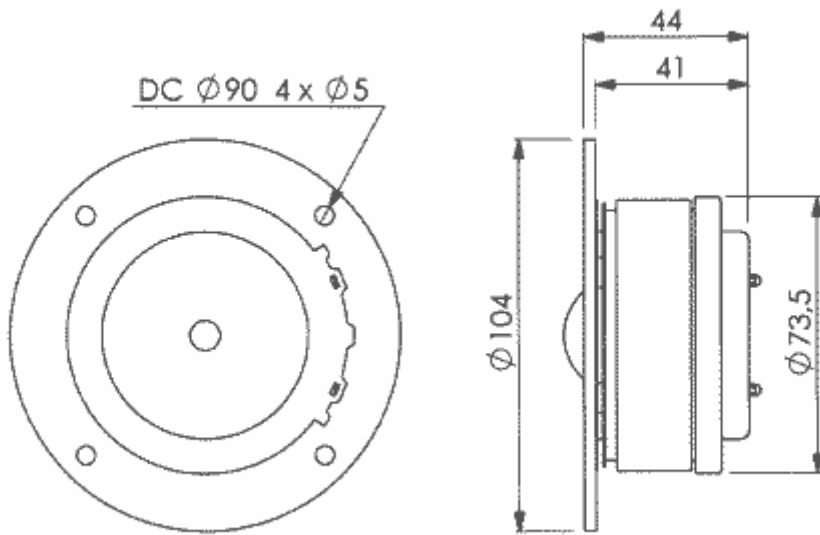

Drawing Dimensions

Outside Diameter	OD	104	mm
Flange Thickness	FT	--	mm
Magnet Diameter	MD	73.5	mm
Cutout Diameter	CD	--	mm
Interior Depth	ID	41	mm
Hole Diameter	HD	5	mm
Screw Circle Diameter	SD	90	mm